

# Motion of a Fan Car



© TERRY G. MCCREA/SMITHSONIAN INSTITUTION

*The assembled fan car*

## INTRODUCTION

You will now begin the first of four lessons in which you will investigate the relationship of force, motion, and energy. In this lesson, you will study the motion of a fan car that you construct using K'NEX™ parts and a battery-powered fan. You will observe the motion of the fan car with the fan turned off and with the fan turned on. In Lesson 19, you will study the motion of a vehicle powered by a mousetrap. Then, in Lessons 20 and 21, you will build a model roller coaster and study the motion of a car moving on the roller coaster. As in previous lessons, you will make predictions, record observations, gather data, and draw conclusions based on evidence from your observations and data.

## OBJECTIVES FOR THIS LESSON

Describe the force exerted by a battery-powered fan.

Describe the motion of a fan car.

Determine the effect of a constant force on the speed of a fan car.

Calculate a fan car's average speed at different times as it moves along a path.

## Getting Started

1. Read “Measuring Motion” on page 177. What does the term “average speed” mean? How do you calculate it? Discuss these questions with the class.
2. Solve the following two exercises to practice calculating average speed.
  - A. A car travels 100 meters (m) in 2 seconds. What is its speed?
  - B. A jogger runs 50 meters in 25 seconds. What is the jogger’s speed?
3. Assemble the fan car as shown in Figures 18.1 and 18.2. Figure 18.1 is an exploded diagram, which shows you the parts needed to make the fan car. Figure 18.2 shows how the parts look in the completed car. Your teacher has a model that you can also examine. Do *not* put batteries in the fan yet.
4. When you are finished, your car should look like the one in the photo at the beginning of this lesson. Check to make sure that it does.

## MATERIALS FOR LESSON 18

### For you

- 1 copy of Student Sheet 18.2: How Fast Is the Car Going?

### For your group

- 1 fan car
- 1 battery-powered fan
- 2 AA batteries
- 1 rubber band
- 1 stopwatch
- 1 meterstick
- 1 piece of adding-machine tape
- 1 piece of masking tape

K’NEX™ parts for the fan car (see Appendix A: Directory of K’NEX™ Parts):

- 8 gray connectors (C1)
- 8 red connectors (C4)
- 8 white rods (R2)
- 4 blue rods (R3)
- 1 yellow rod (R4)
- 3 small wheels (W1)
- 3 small tires (T1) (optional)

Figure 18.1 Exploded view of the fan car

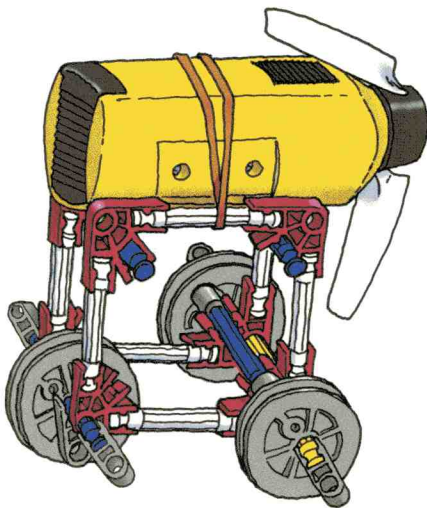
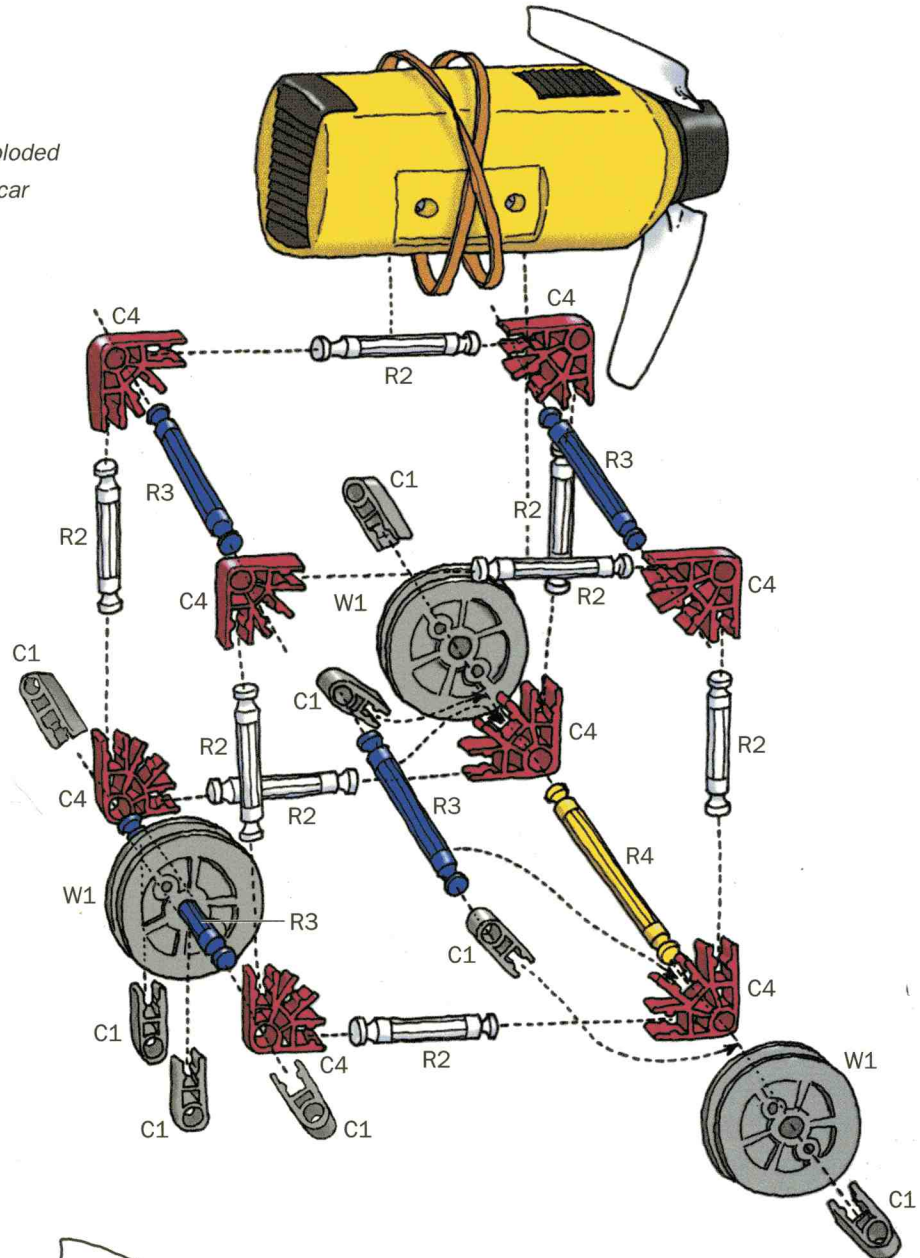

Figure 18.2 The assembled fan car

